

Active Load Emulator for Motor Drive Inverter Development/Production/Quality Testing

System Description:

E&M Power's Active Load Emulator (ALE) mimics the 4-quadrant electrical output of a 3-phase synchronous or induction motor/generator under user-controlled speed, torque and temperature conditions thereby simulating an electric drive train. This electronic dynamometer offers the following advantages:

- Supports multiple motor/generator characteristics in a single set of hardware. Unique machine types (PM, Induction) and characteristics (voltage/speed; inductance; thermal variations) are emulated based on User defined criteria.
- Compatible with most known PWM switching methods (space-vector, sine-triangle, LHC & others)
- Re-circulates power between the ALE and Inverter Under Test thereby wasting only about 10% of the rated power of the Inverter.
- Enables test under extreme operating conditions in a safe mode without harm to the Inverter or Test Equipment (high rate of change, overspeed, continuous overload conditions).
- Dual-mode operation ¹
- Stackable to enable testing of inverters designed to drive more than one motor
- Small footprint supports installation into existing facilities.

1. Modes of Operation: Motor Emulator or Inverter-centric mode/Fixed command mode:

- *Motor Emulator: In this mode the Emulator responds to Inverter motor currents and User Test System speed commands to accurately represent the sinusoidal back EMF voltage of a permanent magnet or induction motor.*
- *Inverter-centric/Fixed command mode: In this mode, the user can specify to the Emulator a given modulation index between 0 and 0.955 and the Emulator shall regulate the three phase output voltage based on the modulation index provided by the User Test System interface.*

Capabilities:

E&M Power has developed and fielded the ALE for a major automotive manufacturer and is ready to customize a unit to your requirements. The output characteristics defined below are based on the fielded ALE, however, our experience with high voltage, high current and high frequency inverters enables us to exceed these levels if required. The next generation of this system has been reduced to one standard 19-inch rack mount cabinet with no side cabinets.

Output Characteristics

Voltage:	560 V
Current:	550 Arms
Power:	300 kW
Fundamental Frequency:	0 to 1500 Hz
Inductance:	150 μ H to 300 μ H



Active Load Emulator for Motor Drive Inverter Development/Production/Quality Testing

System Block Diagram

Comm Data
Mode of Operation
Modulation Index (Fixed Command Mode)
Speed
Initial Rotor Position
Temperature Setting
Motor Parameter Tables
Initialization States
Faults
Feedback

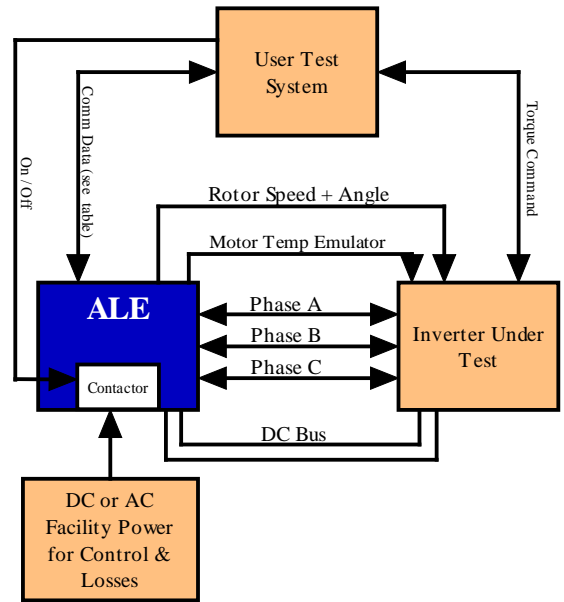

Customizable Options and Required Information:

- Motor models will be generated based on architecture (PM or Induction) and operating characteristics provided by the User. They are coded into Emulator firmware and are selectable by the user enabling one system to emulate numerous electric machines. For each motor, user will provide and download 2-dimensional flux look-up tables (flux versus speed) for desired operating temperatures that will function with the standard motor model in firmware.
- Motor inductances are matched by installing unique emulator inductors or automatic selection of discrete inductances values across a predetermined range.
- Emulator will provide position feedback to the User Test System based on a User identified position sensor characteristic (resolver, encoder).
- Emulator inverter will normally operate in Speed Control Mode and the Inverter under test will operate in Torque Control Mode
- User Test System Interface: E&M and User will jointly determine the architecture (CAN, RS485, etc.) and message protocol for communication between the Emulator and the User Test System.
- Facility Power: A supply rated at least 10% of the Inverter Under Test rating is all that is required since it only provides ALE control and the losses in the ALE and Inverter. All other power is re-circulated. Base unit is configured for an isolated DC Power Supply input. An isolated DC Supply can be provided integral to the ALE to run off of non-isolated facility AC Power.
- Cooling: The ALE will generate waste heat up to 10% of rated capacity.
 - 70% of emulator waste heat is discharged into Liquid coolant provided by Facility.
 - 30% of waste heat can be either discharged into the air through the top of the cabinet (base option) or through the facility liquid cooling system via the use of an internal heat exchanger.
 - For lower power systems air-cooled only is an option

